

DIMENSIONES Y ELEVACIONES EN METROS
DIMENSIONS AND ELEVATIONS IN METRES

AERODROME OBSTACLE CHART - TYPE A (OPERATING LIMITATIONS)

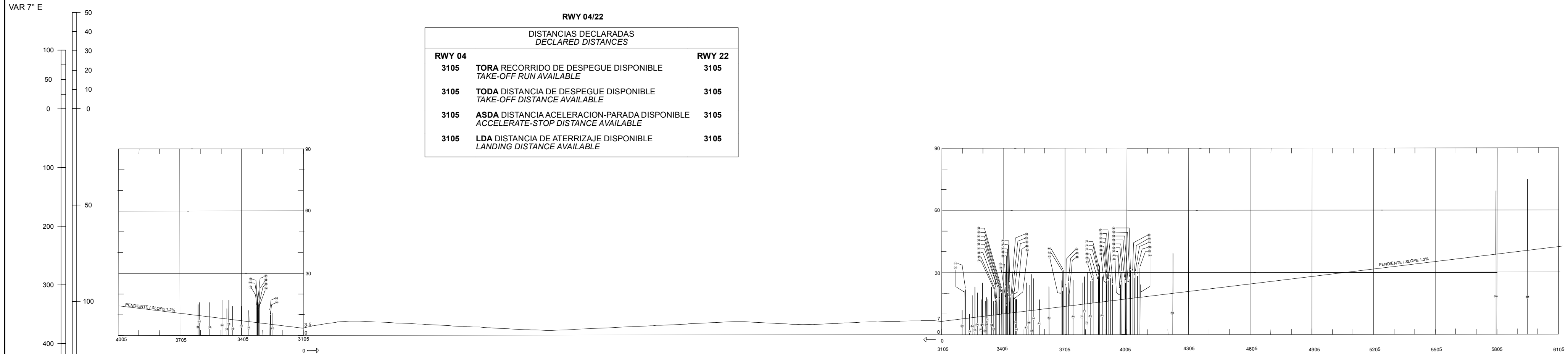

PIES / FEET 500
METROS / METRES 150
Escala Vertical / Vertical Scale 1 : 1,500

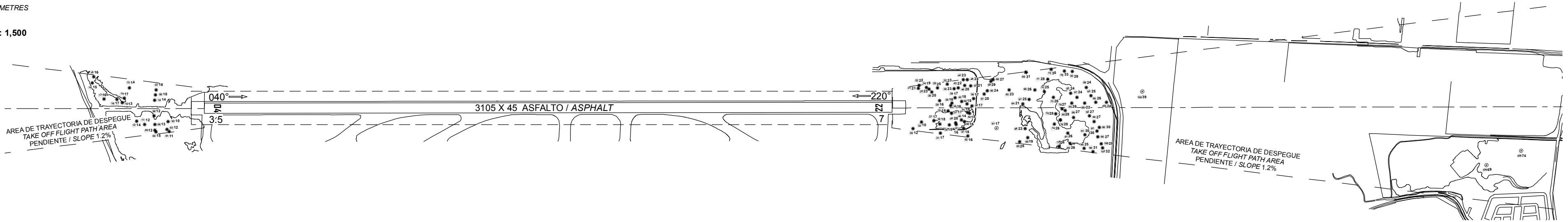

CLAVE / LEGEND	
NUMERO DE IDENTIFICACION IDENTIFICATION NUMBER	①
POSTE, TORRE, CAMPANARIO, ANTENA, ETC POLE, TOWER, SPIRE, ANTENNA, ETC.	⊙
EDIFICIO O ESTRUCTURA GRANDE BUILDING OR LARGE STRUCTURE	■
FERROCARRIL RAILROAD	+++
CURVA DE NIVEL DEL TERRENO TERRAIN CONTOUR	~
TERRENO QUE PENETRA PLANO DE OBSTACULOS TERRAIN PENETRATING OBSTACLE PLANE	▨
ARBOL, ARBUSTO, ETC TREES, BUSH, ETC.	*

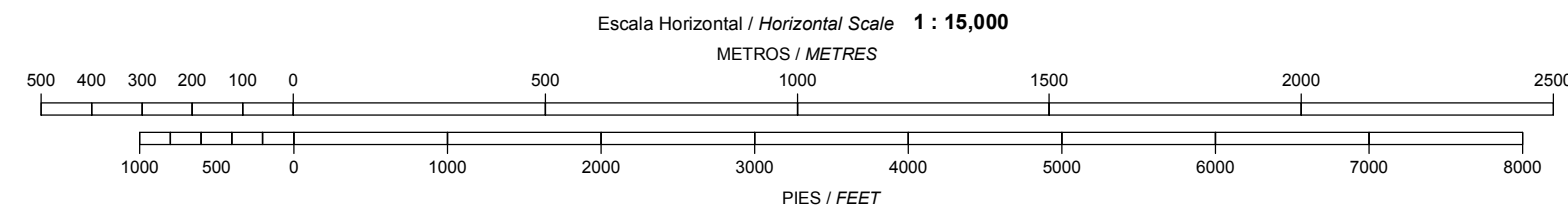

NOTA: ESTUDIO DE OBSTACULOS DE SEPTIEMBRE 2024
NOTE: OBSTACLE SURVEY SEPTEMBER 2024

ORDEN DE PRECISION
ORDER OF ACCURACY
HORIZONTAL 0.5 M
VERTICAL 0.5 M

REGISTRO DE ENMIENDAS / AMENDMENT RECORD		
No.	FECHA / DATE	ANOTADA POR / ENTERED BY
01	MARZO 2025	GAP

CAMBIOS: NIL